



FIRE ALARM SYSTEM

Photoelectric Type Smoke Detector



CM-WT30L

ISO 9001, CE Approved

DESCRIPTION

The photoelectric type smoke detector is based on the photoelectric sensing principle to make up. When fire break out and smoke enters the light-tight box, the particles of smoke scatter the infrared light, and this scattered light goes into the receiving element, thereby emitting an electric current, and while the electric current is up to the fixed extent, the fire alarm will be activated.

This is an advance scientific device. It is very quick and accurate to activate the early fire warning system. Because of the pretty and compact styling, it is most suitable for the interior decoration of the modern buildings.

ADVANTAGES

- With the photoelectric sensing principle, this kind of detectors is activated more quickly, accurately and reliably, and there are no false alarm due to chemicals, exhaust gas, wind and exterior light.
- With stainless steel net of holes' diameter 0.5mm preventing from flying insects and dust particles but no barrier to smoke inflow.
- No harm to man and beast as no radiation source is used.
- Because of the compact styling and pretty outlines, it is most suitable for such modern buildings as employed in the design of decorative smooth ceilings.
- The photoelectric type detector ensures repeated use and by removing the cover can accomplished maintenance easily.
- Connection are non-polarized to avoid wiring mistakes.
- Universal base is interchangeable with the various type detectors' base made in this company, reducing storage and installation costs.

CATALOG NO. CM. 1003

SPECIFICATION

Main Model:CM-WT30L
 Series Model:CM-WT30L1. CM-WT30L3
 Rated Voltage:24V DC
 Working Voltage: 12V to 30V DC
 Standby current:60 micro amps.(max)
 Alarm Current:100milli amps.(max)
 Initial Stabilizing Time:15sec

Identification Light:Red color(LED).
 Ambient Temperature: - 10°C ~ + 50°C
 Ambient Humidity: 0 ~ 95%
 Body Case: Fire-Proof Plastic
 Weight: Approx. 140g.
 Color: Creamy-white.

OPERATION PRINCIPLES

(When smoke entered)

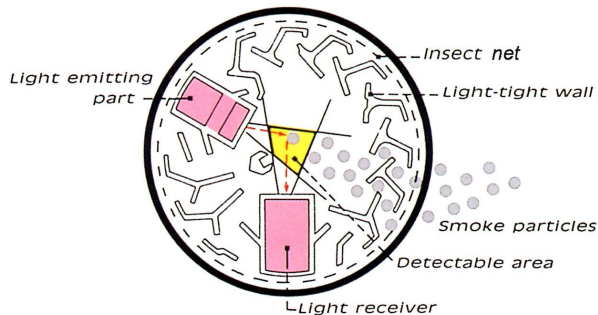

A fire signal is emitted only more than three pulse signals are produced, that is a completely reliable process through thrice confirmations. There are no false alarm due to dust particles, confused pulses and exterior influence.

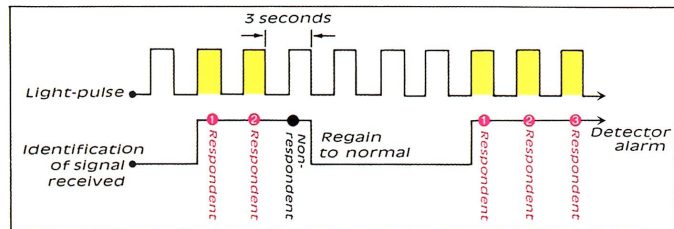

WIRING AND CONNECTION

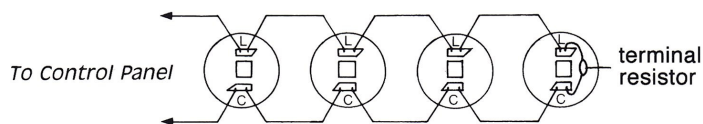

MOUNTING STATUS

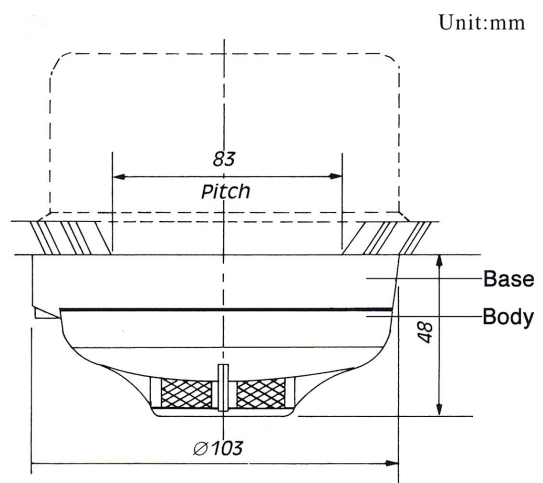

DISTRIBUTOR:

บริษัท ที.เอส.อาร์. - เทเลคอม ซีสเท็มส์ จำกัด
 โทร 02-528-0383 ถึง 7
 Email : sales@tsr.co.th
 Line ID : @tsrtelecom
 Website : tsr.co.th